

M: 304 STAINLESS STEEL MIRROR, 1.2mm

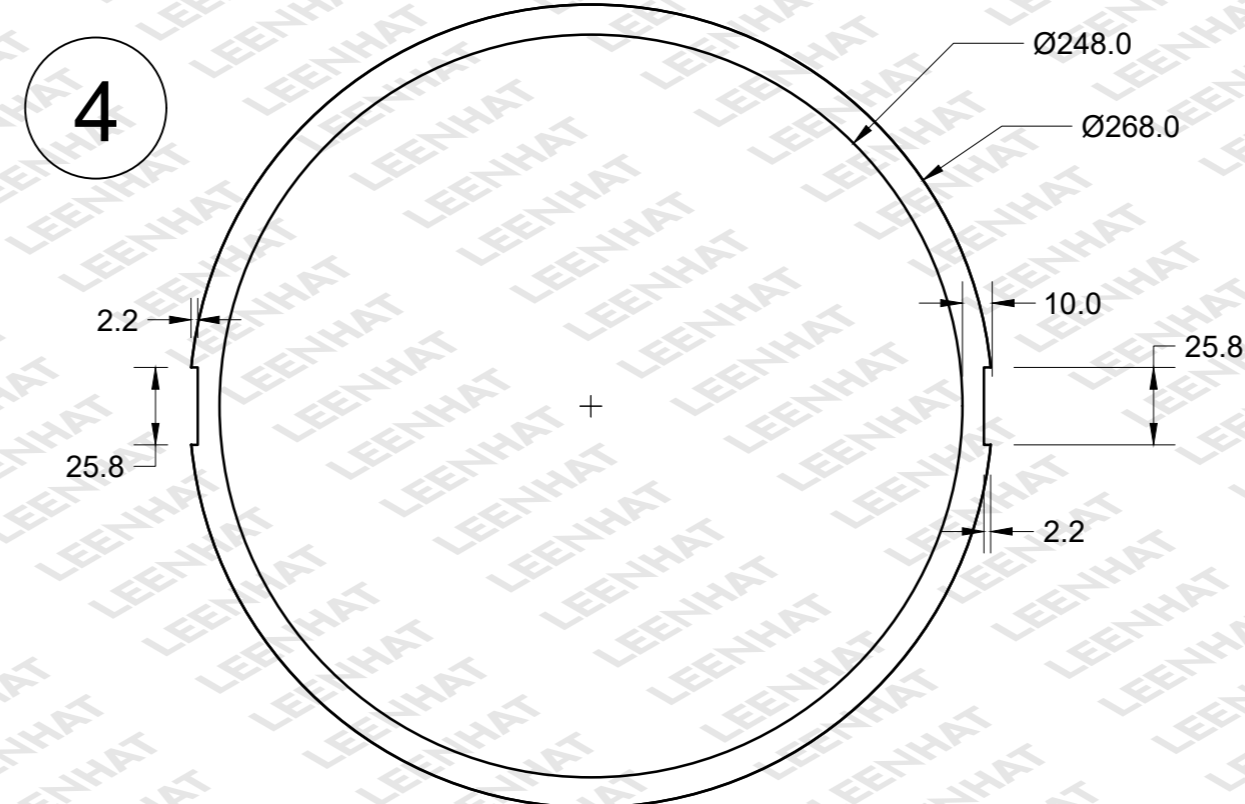

M: 304 HAIRLINE STAINLESS STEEL, 1.2mm

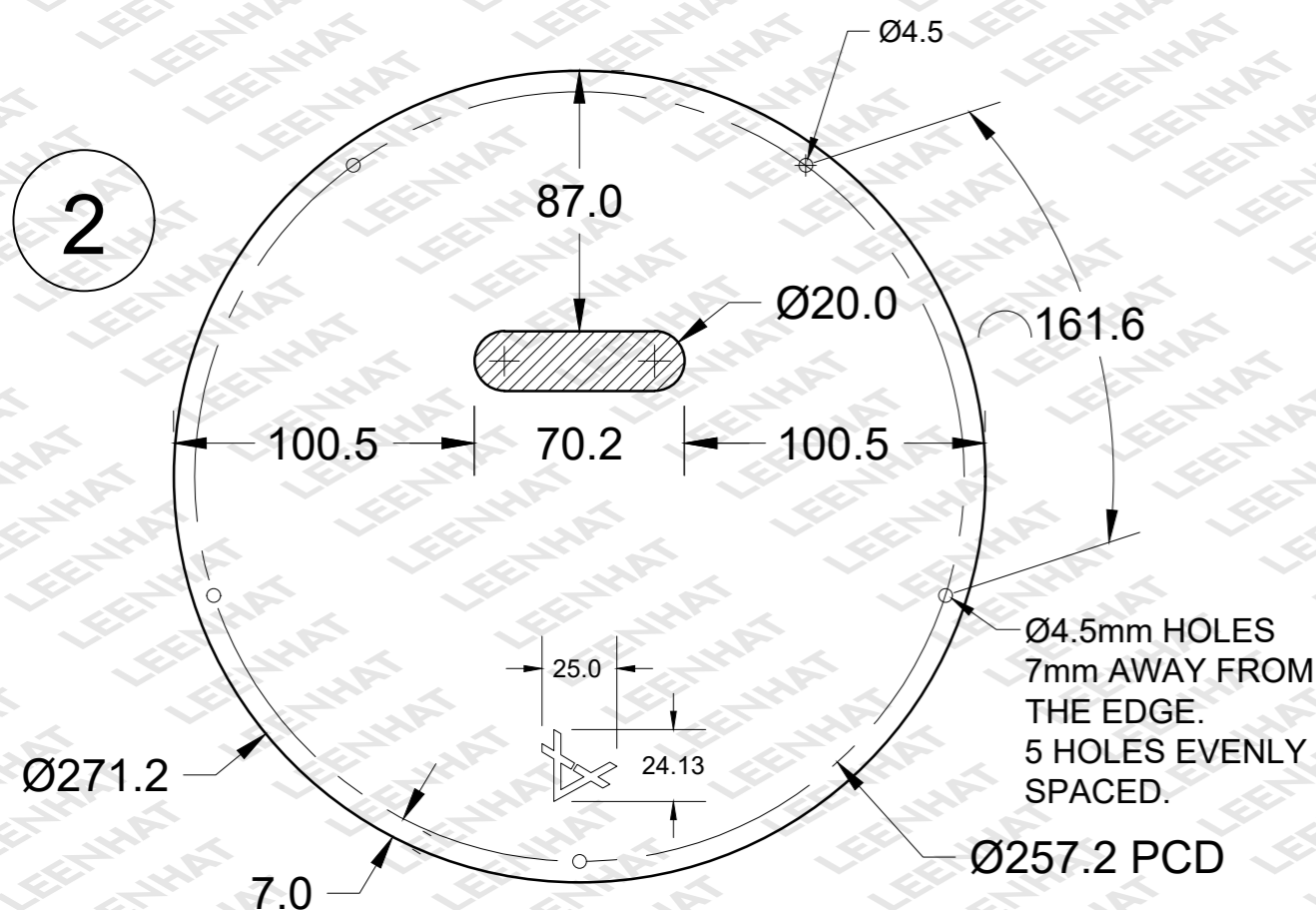

M: 304 STAINLESS STEEL MIRROR, 1.2mm

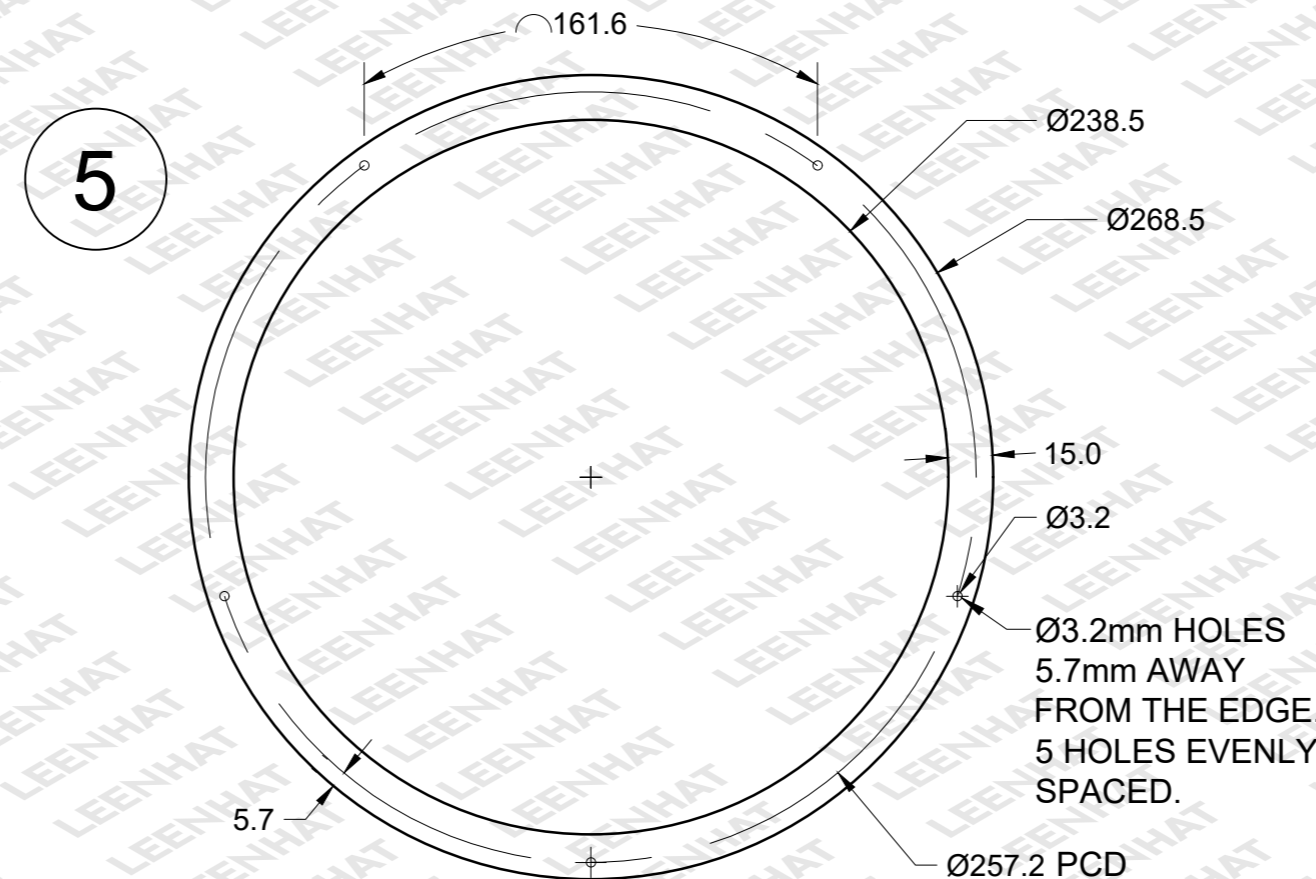

M: 304 HAIRLINE STAINLESS STEEL, 1.2mm

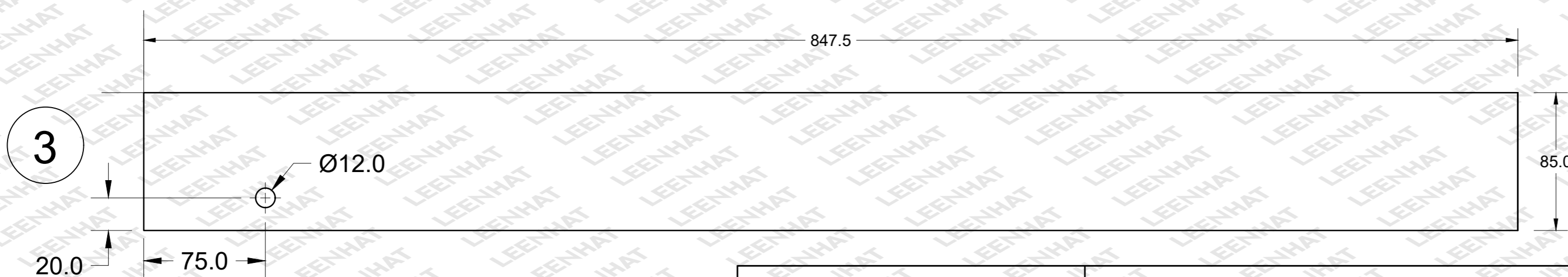

M: 304 STAINLESS STEEL MIRROR, 1.2mm

Rev	Date	Description	Drawn	Checked	Approved
D					
C					
B					
A	04/03/2021	Issued for review.	S.P	JAC	JAC

Material	As Stated
Finish	N/A
Page Size	A2

UNLESS OTHERWISE NOTED:
 ALL DIMENSIONS ARE IN MILLIMETERS (mm).
 TOLERANCES:
 LINEAR: ± 0.00
 ANGULAR: ± 0.00°
 BEND: ± 0.00

Drawing Title :
RECEIVING HANDS (OVER ALL FOR LASER CUT PURPOSE)

Drawing Number ;
 Sheet 1 of 1

Drawn by :
SUKAMAL PATRA

Checked by

Client
JACQSIM

Project
RECEIVING HANDS (OVER ALL FOR LASER CUT PURPOSE)

Designed By ;
LEENHAT
 WWW.LEENHATE.COM

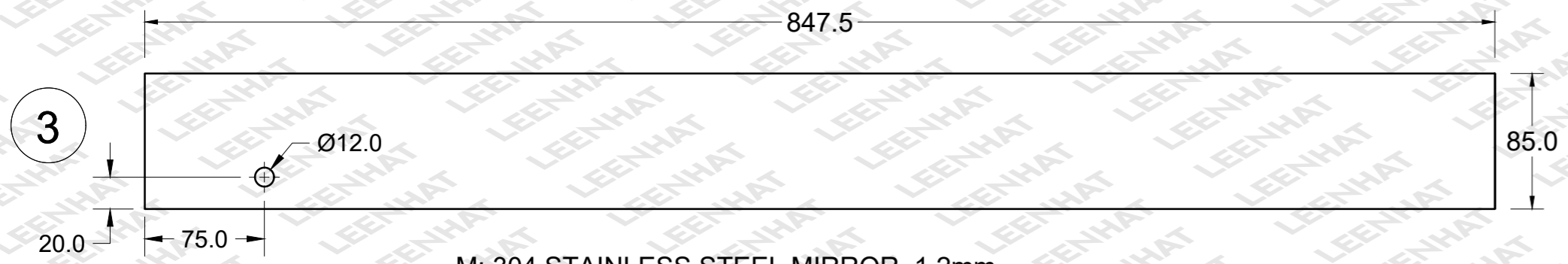

M: 304 STAINLESS STEEL MIRROR, 1.2mm

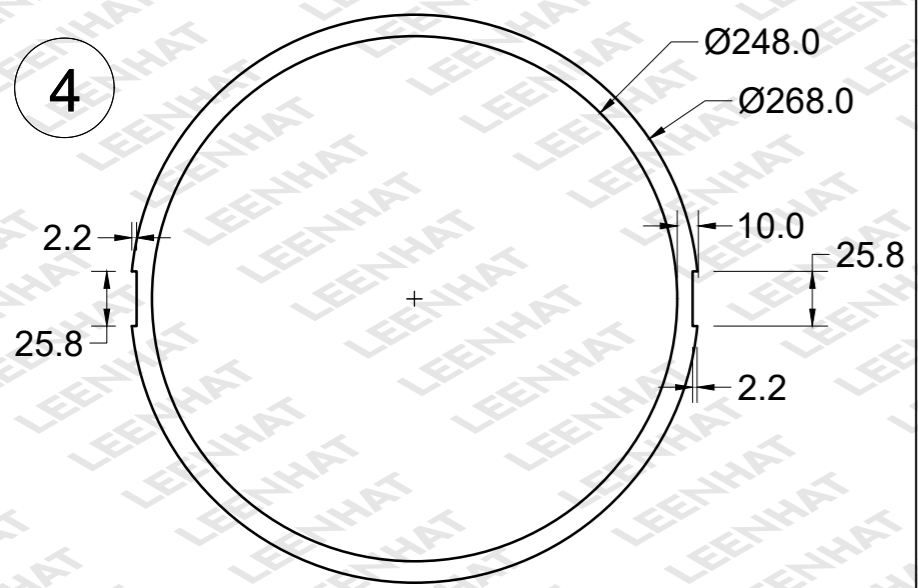

M: 304 HAIRLINE STAINLESS STEEL, 1.2mm

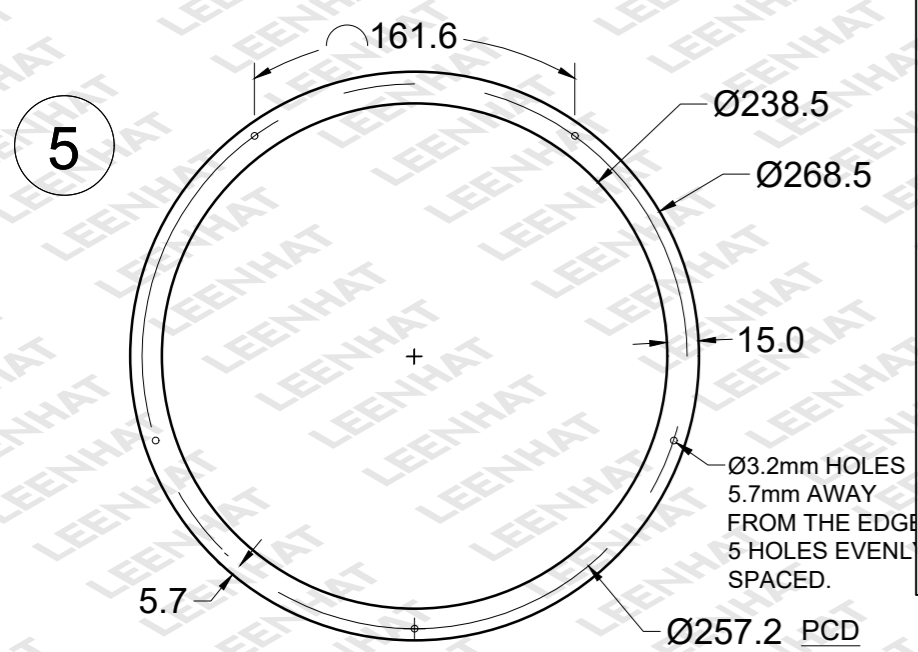

M: 304 HAIRLINE STAINLESS STEEL, 1.2mm

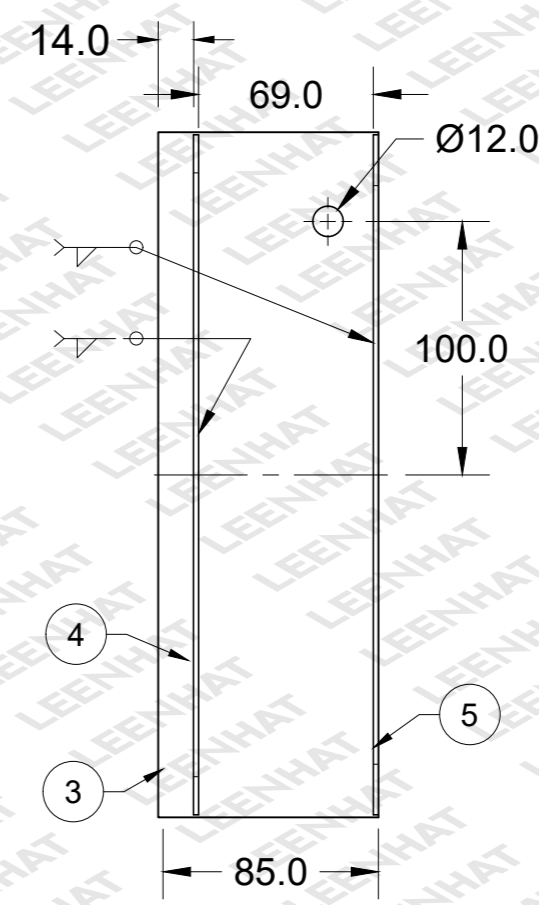
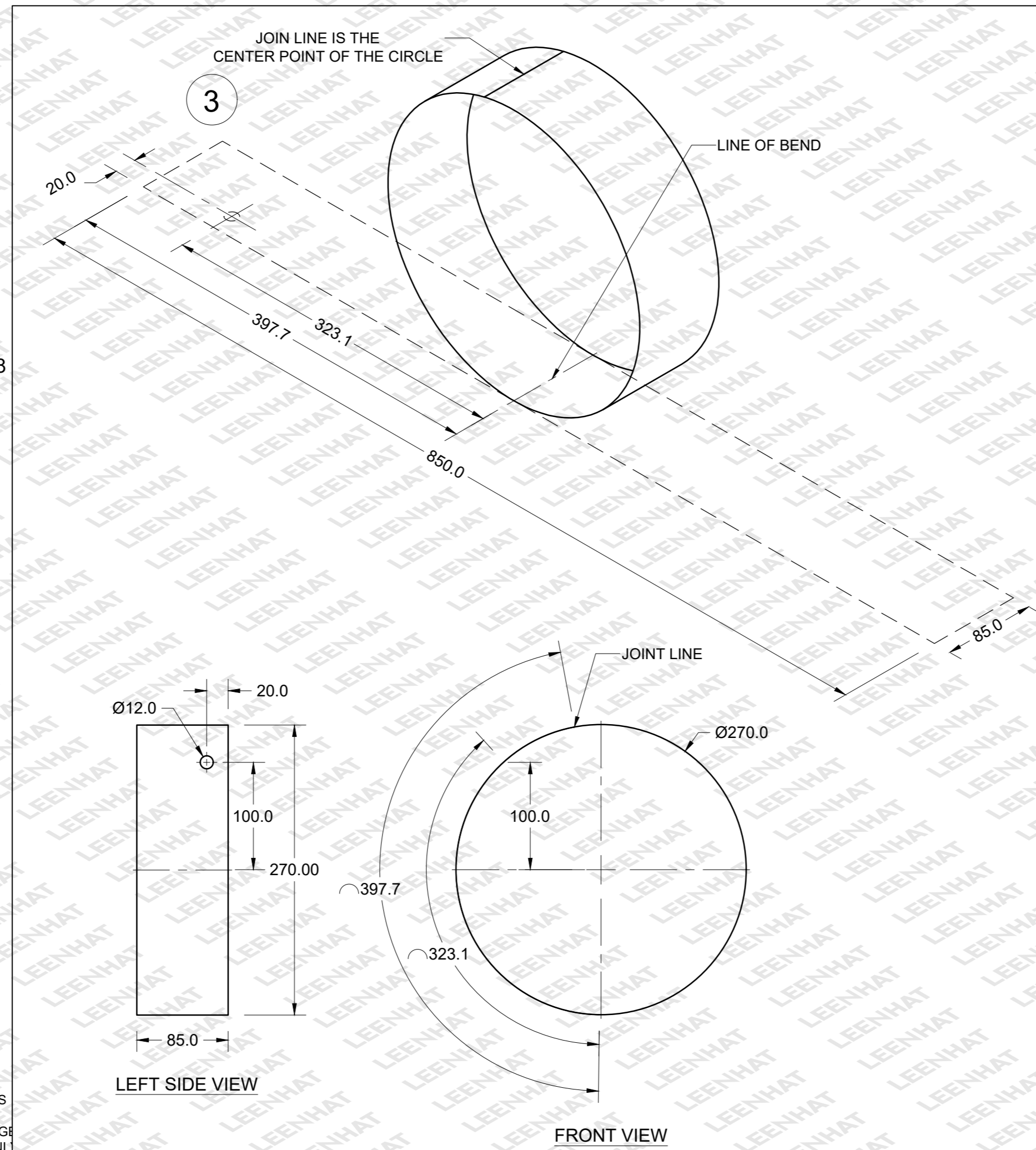

LEFT SIDE VIEW

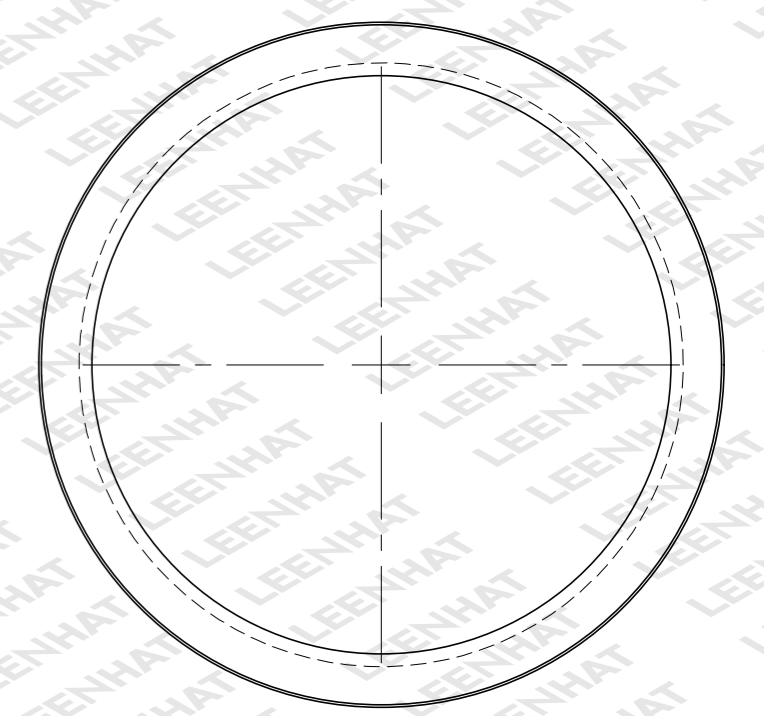

FRONT VIEW

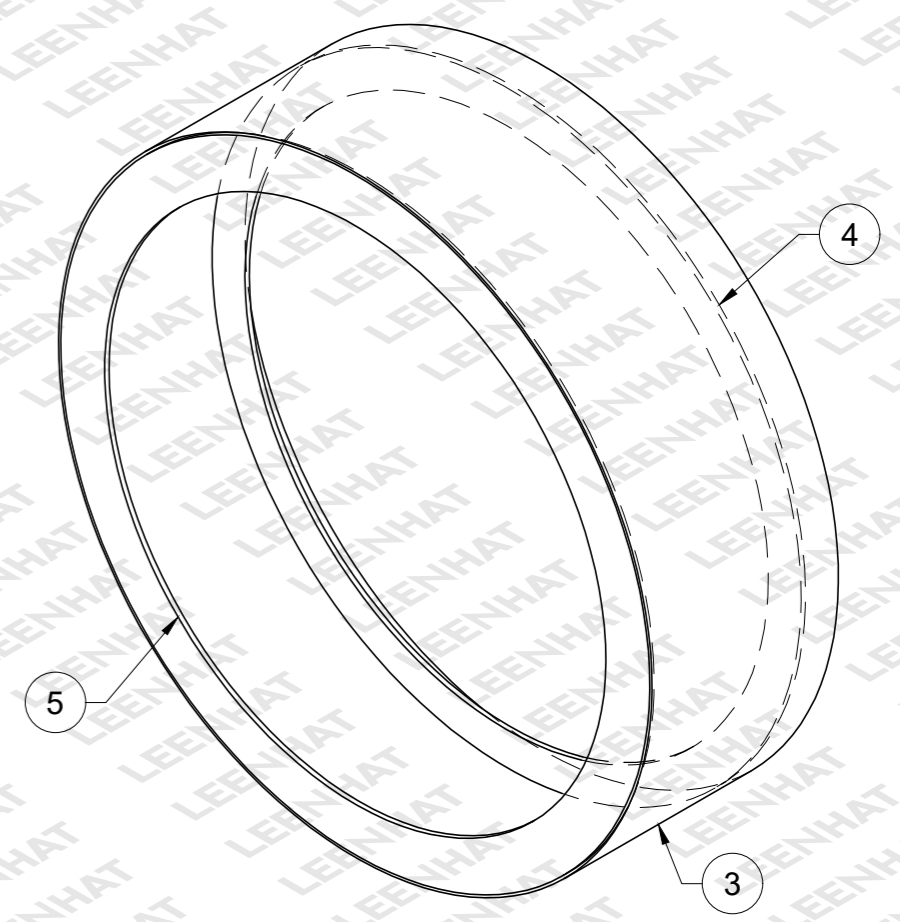

ISOMETRIC VIEW

Rev	Date	Description	Drawn	Checked	Approved
D					
C					
B					
A	04/03/2021	Issued for review.	S.P	JAC	JAC

	Material As Stated Finish N/A Page Size : A2	UNLESS OTHERWISE NOTED: ALL DIMENSIONS ARE IN MILLIMETERS (mm). TOLERANCES: LINEAR: ± 0.00 ANGULAR: ± 0.00° BEND: ± 0.00	Drawing Title : ITEME 3, 4 & 5 ASSEMBLY	Client JACQSIM	Designed By ; LEENHAT
		Process N/A	Drawing Number ; Sheet 1 of 1	Project RECEIVING HANDS (OVER ALL FOR LASER CUT PURPOSE)	WWW.LEENHATE.COM